

EP-6700-48-DX

Motorized Ring Wrapper Deluxe

Bundles Large and Long Objects with Ease!

Measuring 36" in diameter, the Motorized Ring Wrapper Deluxe is designed to encircle and securely bundle large objects (e.g. doors, packages, small furniture), as well as long objects (e.g. aluminum or wood extensions, door frames, piping, lumber). The Deluxe unit includes an adjustable motor, allowing you to customize the speed at which the ring wrapper runs. The film roll mechanism has a tension adjustable middle ring, which holds only 12" standard film or pre-stretch rolls. The unit can be moved easily via forklift.

Features:

- Max box size: 24 x 24"
- Unit Weight: ~500 lbs
- Holds only 12" film rolls (standard film or pre-stretch rolls)
- Tension adjustable
- Foot pedal or button operated
- Adjustable RPM
- Unit comes with stand



MADE IN USA

P (847) 735-8105 | F (847) 735-8297
sales@encorepack.com | www.encorepack.com

201 Park Avenue, Lake Villa, IL 60046
P.O. Box 595, Winnetka, IL 60093 USA

DATA SHEET EP-6700-DX-48

MOTORIZED RING WRAPPER DELUXE



Model/Version	Film Width	Machine Info	RPM
EP-6700-48-DX	12"	110V / 8 A / 60 HZ	0 - 60
Stretch Potential	Cord Length	Ring Dimensions	Weight
10% – 30%	Power Cord: 9' / 2.7 m Foot Pedal Cord: 9' / 2.7 m	Radius: 18" / 457.2 mm Diameter: 36" / 914.4 mm	Unit: ~500 lbs / 226.8 kgs

Dimensions

Length: 55.5" / 1.40 m (w/ handles)

Width: 58 1/8" / 1.47 m (w/ motor)

Height: 52.25" / 1.33 m

Height w/ Stand: 73.75" / 1.87 m

Roller Height to Table:

55.5" / 1.5 m MAX

36" / 914 mm MIN

Stand Dimensions

Length: 27.5" / 698.5 mm

Width: 52" / 1320.8 mm

Height: 21.75" / 552.45 mm

Max Box Size

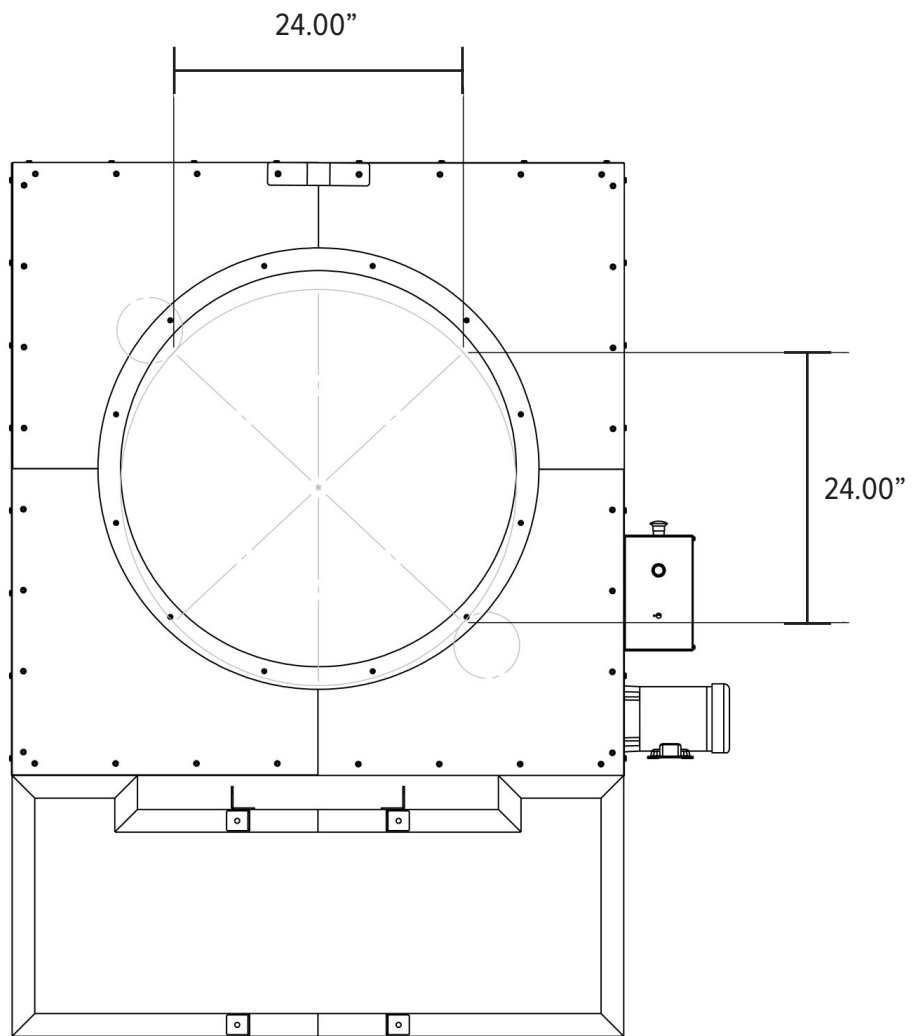

P (847) 735-8105 | F (847) 735-8297
sales@encorepack.com | www.encorepack.com
201 Park Avenue, Lake Villa, IL 60046
P.O. Box 595, Winnetka, IL 60093 USA